

## BC 125 EX beacon / light

SIL2 compliant as IEC 61508 & IEC 61511



The BC125 flameproof beacon is ATEX IECEx Certified for use in potentially explosive atmospheres, helping to signal alarms, alerting personnel to potential dangers or signal the need for immediate action in emergency situations. The BC125 can also be used as part of a status light array.

**ATEX / IECEx Certification:** ATEX Zone 1 & 2 for gas and Zone 21 & 22 for dust/powder. SIL2 compliant as IEC 61508 & IEC 61511.

**Application:** Oil and gas, chemical, petrochemical, pharmaceutical, marine and offshore applications.

**Key features:** Robust and highly reliable, it is designed for corrosive environments and hazardous areas. Housing is made of stainless steel 316L covered with UV resistant paint and the lens is made of borosilicate glass available with a 316L stainless steel lens guard option.

**Options:** This beacon can be delivered with two different light sources;

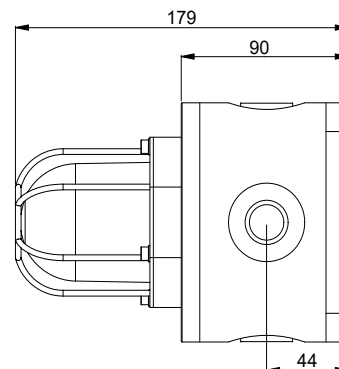
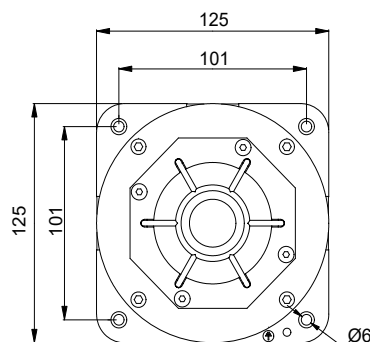
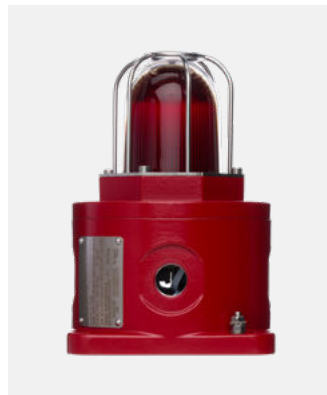

- LED with steady, rotary or flashing options of different intensity.
- Flashing with XENON tube of different intensity.
- Four flashing frequencies are selectable.

A range of accessories is available to customise this product. These include pipe mounting brackets, sunshades, tag and duty labels and other accessories.



# BC 125 EX beacon / light

SIL2 compliant as IEC 61508 &amp; IEC 61511

MATERIAL	• <b>Enclosure:</b> Stainless steel 316L • <b>Lens:</b> Tempered borosilicate glass 3.3					
HOUSING COLOUR	• RED : RAL3001		• YELLOW : RAL1018		• BLUE : RAL5005	
	• BLACK : RAL9005		• GREEN : RAL6032		• GREY : RAL7038	
	• ORANGE : RAL2010					
INGRESS PROTECTION	• IP66/67					
AMBIENT TEMPERATURE FOR OPERATION	• <b>T6</b> = - 40°C ~ + 55°C , <b>T5</b> = - 40°C ~ + 60°C, <b>T4</b> = - 40°C ~ + 70°C					
CERTIFICATION	• <b>Presafe</b> 16 ATEX 8967X, IECEX PRE 16.0087X					
EX CODE	 • II 2 GD Ex db IIC T4 ~ T6 Gb • Ex tb IIC T135°C ~T85°C Db					
STANDARD	• EN / IEC 60079-0, EN / IEC 60079-1, EN / IEC 60079-31					
ATEX AREA ZONE	• <b>Gas zone:</b> 1 & 2 <b>Dust zone:</b> 21 & 22					
CANDELA LENS COLOUR	• Red: 0.15 • Amber: 0.51 • Blue: 0.12 • Green: 0.49 • Yellow: 0.85 • Clear: 1					
LIGHT TYPE	<b>Flash tube (XENON)</b>			<b>LED</b>		
TRUE LIGHT INTENSITY	• <b>5 joules</b> = 109 Cd		• <b>10 joules</b> = 293 Cd		• <b>5 W</b> = 128 Cd	
	• <b>15 joules</b> = 395 Cd		• <b>21 joules</b> = 424 Cd		• <b>10W</b> = 312 Cd	
PEAK LIGHT INTENSITY	• <b>5 joules</b> = 35970 Cd		• <b>10 joules</b> = 66804 Cd			
	• <b>15 joules</b> = 83345 Cd		• <b>21 joules</b> = 95824 Cd			
LIFETIME	• Emissions are reduced to 70% after 8 million flashes			• >50 000 hours without luminosity decreasing		
BLINKING OR ROTARY FREQUENCY (0 = steady status)	• 60/80/120 times/min • 100/120/150 times/min • 120/150/180 times/min • 75/95/120 times/min			• 60/75/0 times/min • 60/75/1 00 times/min • 75/95/0 times/min		
CONSUMPTION	• <b>5 joules</b> = 10W • <b>15 joules</b> = 20W		• <b>10 joules</b> = 15W • <b>21 joules</b> = 25W		• <b>5W</b> • <b>10W</b>	
AMBIENT HUMIDITY*	• Up to 95%*					
POWER SUPPLY	• 12-48V DC • 115-230V AC NOMINAL (100 - 240V AC Range)					
RATED IMPULSE WITHSTAND VOLTAGE	• 1kV following IEC 61000-4-5					
WORKING CURRENT LED	• <b>Power</b>	<b>12V DC</b>	<b>24V DC</b>	<b>48V DC</b>	<b>110V AC</b>	<b>220V AC</b>
	• <b>5W</b>	530 mA	260 mA	120 mA	80 mA	40 mA
	• <b>10W</b>	1100 mA	530 mA	240 mA	160 mA	80 mA
WORKING CURRENT XENON	• <b>Energy</b>	<b>12V DC</b>	<b>24V DC</b>	<b>48V DC</b>	<b>110V AC</b>	<b>220V AC</b>
	• <b>5J</b>	460 mA	280 mA	140 mA	60 mA	35 mA
	• <b>10J</b>	850 mA	490 mA	250 mA	100 mA	60 mA
	• <b>15J</b>	1200 mA	700 mA	360 mA	140 mA	80 mA
	• <b>21J</b>	NA	960 mA	480 mA	180 mA	110 mA
CABLES ENTRY	• 4 x M20, 1 x M25 & 3 x M20, 1 x 1/2" NPT & 3 x M20, 1 x 3/4" NPT & 3 x M20. Additional adaptors can be supplied as well as cable glands, please specify.					
TERMINAL	• From 22 to 14 AWG - from 0.50 mm <sup>2</sup> to 2.5 mm <sup>2</sup>					
NET WEIGHT	• 5.1 Kg					

\* = without runoff - \*\* = optional (cable gland and blanking plugs can be supplied if required)

Phone: +44 (0)1752 333 933 | E-mail: [sales@ex-techsignalling.com](mailto:sales@ex-techsignalling.com) | Website: [www.ex-techsignalling.com](http://www.ex-techsignalling.com)

Ex-tech Signalling Bell Close, Plympton, Devon, PL7 4JH, UK

Please note that whilst effort has been made to ensure the accuracy of this datasheet. Ex-tech Signalling will not assume liability for the use thereof. Ex-tech Signalling reserves the right to improve specifications without prior notice, please refer to our website for updated information or contact our local sales representative.

# BC 125 EX beacon / light

SIL2 compliant as IEC 61508 & IEC 61511

Product	Certification	Lens colour	Light type	Supply	Duty label	Tag label	Lens guard	Connection	Housing colour	Standard
BC	125	R	X10	DC	N	Y	Y	A	RD	N



BC	= BEACON									N/A
125	= HAZARDOUS AREA									
126	= NON-CERTIFIED									
R	● = RED									RD ● = RED (STD)
A	● = AMBER									YW ● = YELLOW
B	● = BLUE									BU ● = BLUE
G	● = GREEN									BL ● = BLACK
Y	● = YELLOW									GN ● = GREEN
C	○ = CLEAR									GY ● = GREY
										OJ ● = ORANGE
										OR ○ = OTHER
X05	= XENON 5J									A = 4 x M20 x 1.5
L05	= LED 5W									B = 1 x M25 x 1.5 & 3 x M20 x 1.5
X10	= XENON 10J									C = 1 x 1/2" NPT & 3 x M20 x 1.5
L10	= LED 10W									D = 1 x 3/4" NPT & 3 x M20 x 1.5
X15	= XENON 15J									Additional adaptors can be supplied as well as blanking plugs and cable glands, see below.
X21	= XENON 21J									Y = YES
DC	= 12 - 48V DC									N = NO
AC	= 100 - 240V AC									Y = YES
Y	= YES (SEE LIST)									N = NO
N	= NO									

CONDUIT ACCESSORIES	
M20 316L St. St Exd conduit plug	SPARE3060009
M25 St. St. conduit adaptor	SPARE3060105
½" NPT St. St. conduit adaptor	SPARE3060108
¾" NPT St. St. conduit adaptor	SPARE3060107
St. St Exd cable gland 7-12mm	SPARE3060108
St. St Exd cable gland 10-16mm	SPARE3060109

CONDUIT ACCESSORIES	
M20 NPB Exd conduit plug	SPARE3060008
M25 NPB conduit adaptor	SPARE3060003
½" NPT NPB conduit adaptor	SPARE3060001
¾" NPT NPB conduit adaptor	SPARE3060002
NPB Exd cable gland 7-12mm	SPARE3060019
NPB Exd cable gland 10-16mm	SPARE3060018

## BC 125 EX beacon / light

SIL2 compliant as IEC 61508 &amp; IEC 61511

**Meaning of lens colour usage in the international standard (IEC 60073)**

Colour	Meaning	Action	Example
● RED	EMERGENT	Dangerous state. Take immediate action.	Pressure/Temperature beyond the safe state - Shutdown due to the action of protective devices - Fire alarm - Equipment failure alarm
● AMBER ● YELLOW	ABNORMAL	Abnormal state, near the critical status	Pressure/Temperature above the normal range - Protective device released - Toxic and harmful gases release alarm
● GREEN	SAFE	Normal state	Pressure/Temperature in normal state - Automatic control system is operating normally
● BLUE	MANDATORY	Requires operator's action	Emergency evacuation - Abandon rescue and escape - Abandon platform or abandon ship - Enter the command
○ CLEAR	NO SPECIAL SIGNIFICANCE	If uncertainty for other colors, clear is allowed to be used	General information - Can't exactly use red, yellow, green or blue - Used for the implementation of command - Indicate the measured values